



ensorcell
VERSAWELD.

User manual

ensorcell.
VERSAWELD™

Table of contents

Introduction

Product introduction.....	4
Important safety information	6
Safety symbol key	7

Component overview

Component list	11
Specifications	15
Tubing capacity	17
Durability performance	18
Power and charging	19
Digital interface use and navigation	21

Welding processes

Tube selection	24
Wheel position.....	25
Placing and securing tubes.....	26
Welding tubes.....	28
Weld integrity inspection	30

Features and functions

Pop-up windows.....	31
Cassette replacement	32
Tube gauge use	36
Weld tubing guides	38

Settings

Settings menu	39
Change cassettes	40
Product resources	40
Screen brightness	41
Firmware updates	43
Instrument information	44
Accessing technical support	44

Troubleshooting guide

General troubleshooting	45
Cleaning instructions.....	49
Servicing and technical support	50
Standard accessories.....	51

Introduction

Ensorcell's Versaweld tube welder is a sterile tube welding instrument for research purposes, designed to cut and weld tubes in a variety of sizes and materials (see the Tubing capacity section). The tube welder is intended to function in a laboratory setting using a cassette with a spooled stainless-steel ribbon to allow for multiple sterile welds to be performed without changing the cutting implement. This ribbon performs cutting and allows for fusing operations on sterile tube segments.

The tube welder can perform dry-to-dry, dry-to-wet, or wet-to-wet welds. The cassette also has an air filter, which limits user exposure to typical fumes resulting from the melting and fusing of tubes during the welding operation.

The system includes a mobile, battery-operated base unit, comprised of two clamp fixtures with selector wheels incorporated to accommodate multiple diameters of tubing. The system has an auto-feeding cassette of spooled ribbon. The cassette can be replaced as needed. The user interacts with a touchscreen to manage the weld operation and other related system functions. The user also interacts with the two clamp fixtures and selector wheels in order to secure and weld tubing.

This manual is provided for informational and guidance purposes only and does not constitute a contract or legally binding agreement of any kind between Ensorcell or any of its affiliates and the user of this manual, whether such user is an owner, user, or purchaser of the Ensorcell Versaweld tube welder, a representative, agent, employee, or contractor of any such party, or otherwise connected to the Ensorcell Versaweld tube welder (any such party, a "User").

TO THE FULLEST EXTENT PERMITTED BY APPLICABLE LAW, NOTHING IN THIS MANUAL CREATES ANY EXPRESS OR IMPLIED WARRANTY, INCLUDING ANY IMPLIED WARRANTY OF MERCHANTABILITY OR FITNESS FOR A PARTICULAR PURPOSE, OR ANY CONTRACTUAL OBLIGATION ON THE PART OF ENSORCELL OR ANY OF ITS AFFILIATES.

This manual may not be modified or supplemented by any oral representation, and its contents are subject to change without notice.

Important safety information

IMPORTANT - READ ALL INSTRUCTIONS AND WARNINGS CAREFULLY BEFORE USING THE VERSAWELD TUBE WELDER. FAILURE TO DO SO OR OPERATE THE INSTRUMENT AS DESCRIBED COULD CAUSE SERIOUS PERSONAL INJURIES, PROPERTY DAMAGE, A BREACH OF THE EXPRESS WARRANTY AND/OR PRODUCT MALFUNCTION.

The Versaweld tube welder is intended for use by **trained individuals in laboratory and research settings**.

- Do not use any tubing connected to a person
- Do not use on any tubing intended for medical treatment or diagnostic purposes

Throughout this manual, there are WARNINGS and CAUTIONS used to emphasize critical and important information.

Safety symbol key



WARNING

A **WARNING** informs the operator of a potential hazard or unsafe practice that could result in personal injury, affect the operator's health, contaminate the environment, compromise the safety and integrity of products or potential for instrument failure.



CAUTION

A **CAUTION** includes information regarding any special care to be exercised by the operator for safe and effective use of the instrument.



ELECTRICAL HAZARD

Contact with electrical components can result in electric shock / injury. Do not touch.



KEEP DRY

Exposure to moisture can result in damage to the instrument and electrical shock / injury. Keep dry at all times.

Limitations

The welds made by the Versaweld tube welder, when following the instructions for use, are designed to have tensile strength as provided within ISO 3826 and to maintain a sterile environment for fluid transfer; however, it is ultimately the responsibility of the end user to check and validate the tube welder for suitability for specific laboratory requirements. This manual is for the exclusive use of operating the Versaweld tube welder and its accessories, as intended and described herein. Unauthorized reproduction, modification, or use for any other purpose is strictly prohibited.

Misuse of the product or using this manual outside its intended application may void warranties and pose safety risks. The Versaweld tube welder is designed for research and industrial applications, not for medical applications. It is the responsibility of the user to determine if the instrument is suitable for desired field applications.

Examine welds thoroughly before opening the tubing flow path.



This product may contain one or more substances or chemicals known to cause cancer or birth defects or other reproductive harm.

For more information, go to www.P65Warnings.ca.gov.

If the Versaweld tube welder is used in a manner not specified in this manual, the protection provided by the instrument may be impaired.

CAUTION:



Ensure the clamps are down when the cassette bed is raised to change the cassette.



Do not attempt to physically stop the cassette bed from rising.



When the cassette bed is in motion, keep fingers clear of all gaps in the enclosure. Do not touch the bed.



Do not attempt to remove the cassette from the cassette bed until prompted to do so by the display.



Do not handle the cassette by the ribbon.



Do not pull on the ribbon or attempt to unspool it by hand.



Do not attempt to adjust the ribbon tension by turning the cassette spindle by hand.



The Versaweld tube welder should be placed on a level surface prior to welding and maintained in a level state during welding.



Ensure a sufficient length of tube is allocated to waste tube per the use instructions.



Do not handle the cassette by the ribbon.





















Do not pull on the ribbon or attempt to unspool the ribbon by hand.



If the cassette ribbon breaks, remove the cassette from the tube welder and dispose of it in an appropriate waste container per laboratory standard operating procedure (SOP).

WARNINGS:

-  The Versaweld tube welder is not to be used on tubing connected to a patient.
-  The instrument is not meant to be used in a medical capacity.
-  Do not power on the instrument if the enclosure has been damaged or the battery is exposed.
-  Do not attempt to open the cassette or access the waste ribbon or filter of a consumed cassette.
-  Do not attempt to touch the ribbon while the instrument is welding.
-  The ribbon and tubes will be hot during the welding process.
-  Remove the power cord before cleaning.
-  Keep hands clear of the clamp when opening and closing the clamps.
-  Clamp opening and closing creates a potential pinch hazard.
-  Do not attempt to open the clamps mid-weld.
-  Follow laboratory standard operating procedure (SOP) for proper disposal of the waste ends to prevent any leaking of fluid waste.
-  Do not place hands on the springs at the rear of the clamps. Springs in motion are a hand-safety risk.
-  The tube selector wheels shall not be rotated while the instrument is performing weld operation.
-  Do not lean directly over the instrument during welding.
-  Ribbon depyrogenation process produces smoke, which can be harmful when inhaled.
-  Do not spray cleaning solvents directly into the tube welder.
-  Incorrect tube settings (see the Tube selection section) can result in incomplete welds, fluid leakage, and loss of sterility from improperly sealed tubes. Verify the tube material, outer diameter, and inner diameter (see the Tube gauge section for more information).
-  Limit exposure of internal instrument components to liquids. If significant liquid exposure occurs, power off and unplug the instrument from the power adapter. **Contact Ensorcell** support for further troubleshooting.

Component overview

Bottom face

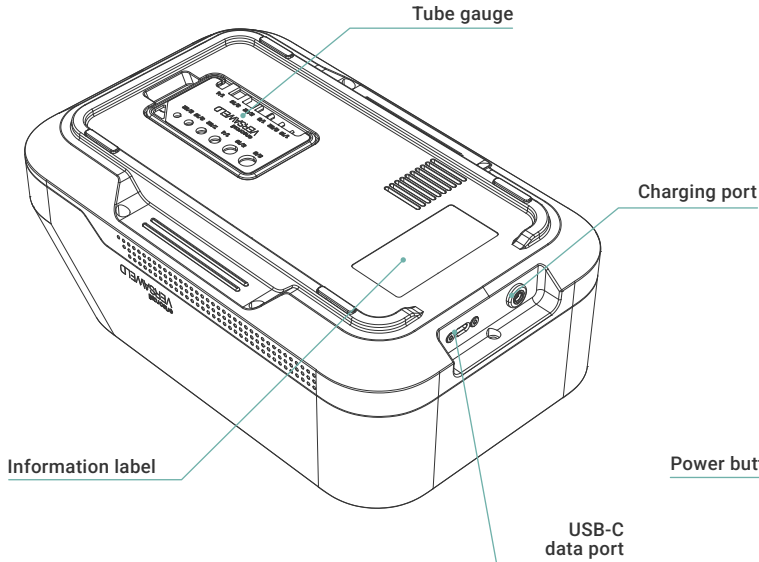

Top face

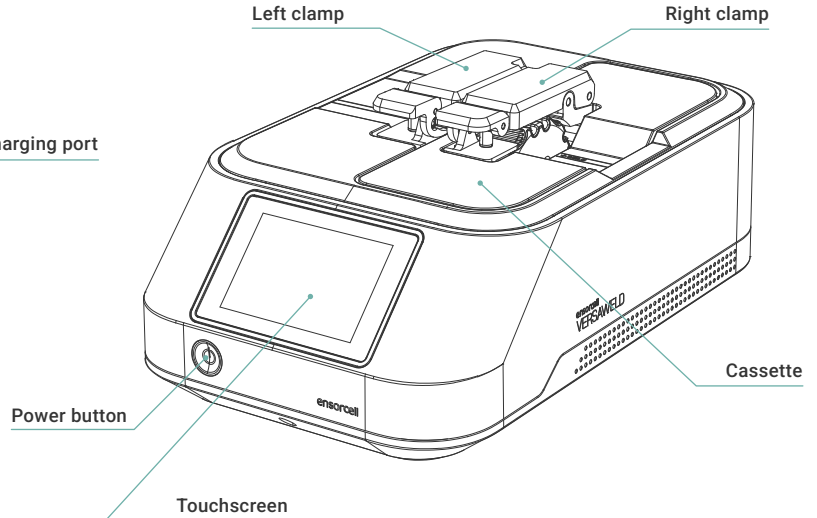

Inner components

Tube selector wheels

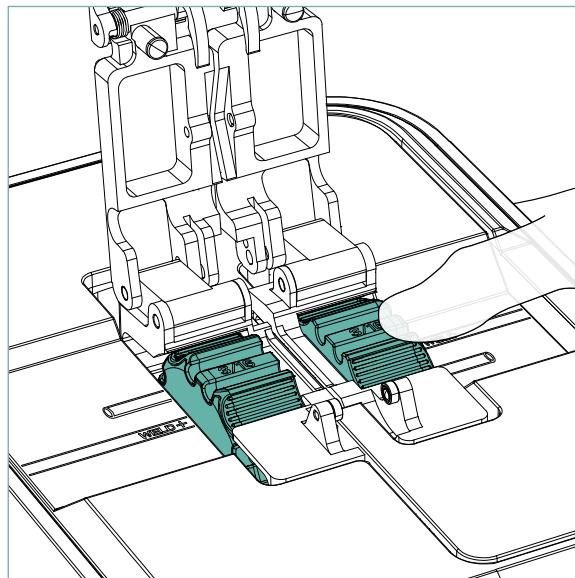
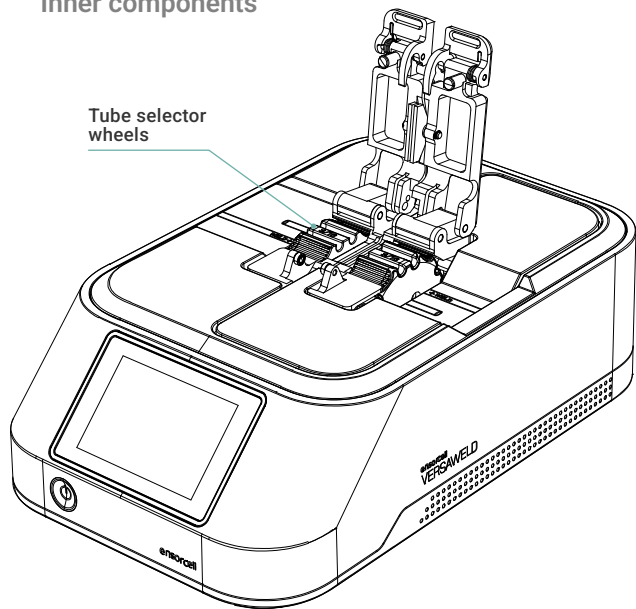

Cassette

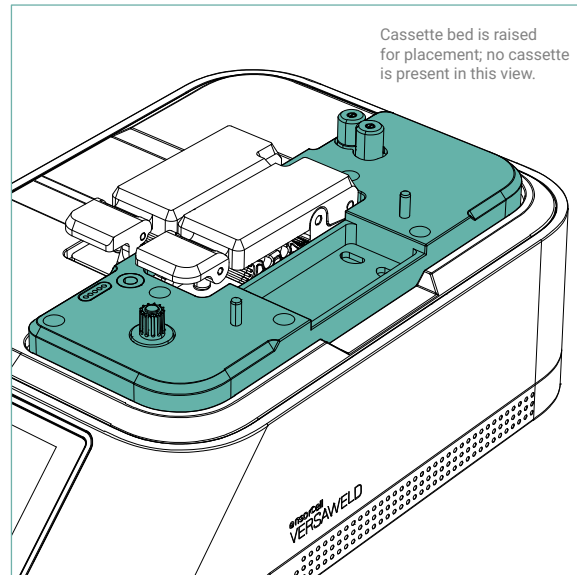
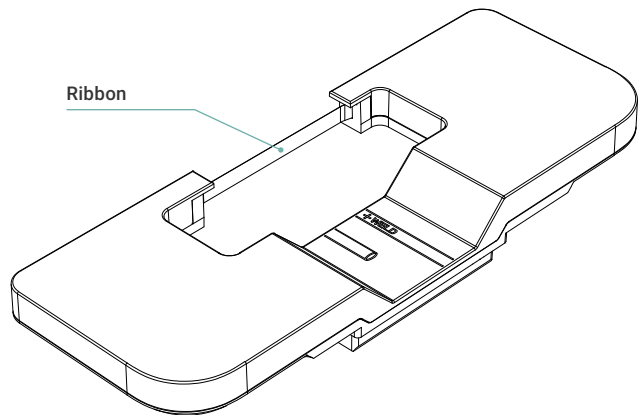

Power adapter

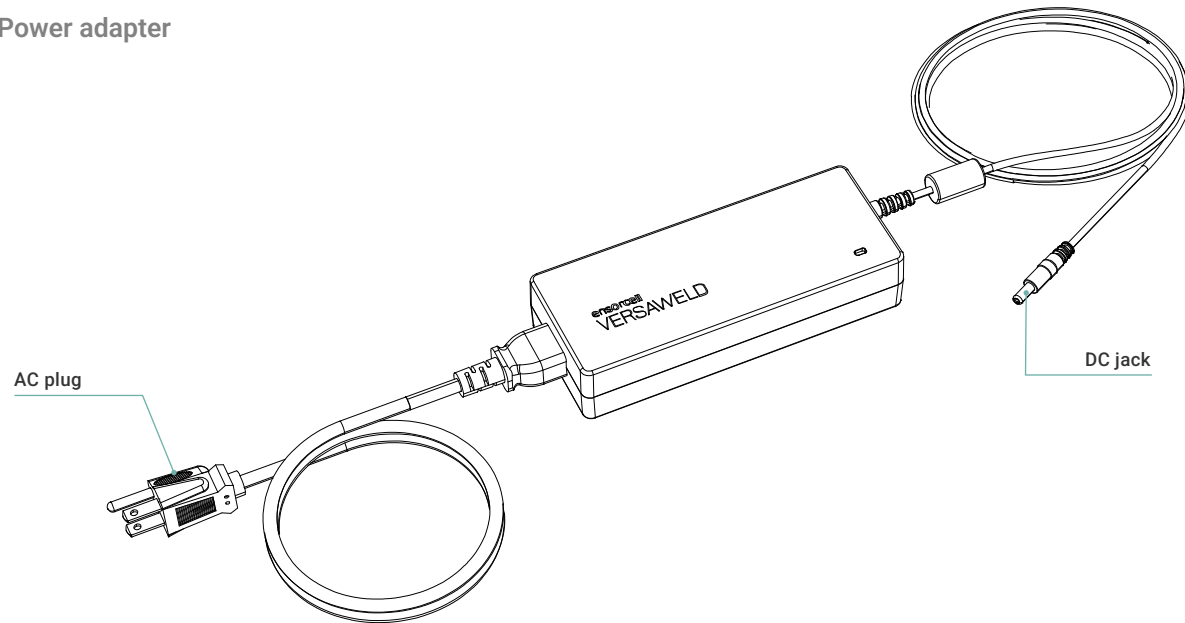

Specifications

Name: Versaweld tube welder | Model: VSWIr-02001

Tubing material:

- Advantaflex
- C-Flex
- PharMed BPT
- PVC



Tubing size (see the Tubing size chart):

- Inner diameter (ID): 0.063 to 0.250 inches
- Outer diameter (OD): 0.156 to 0.375 inches
- Wall thickness: 0.031 to 0.063 inches

Operating conditions:

- Ambient temperature: 5 °C to 40 °C
-  Humidity: 80% relative humidity for temperatures up to 31 °C, decreasing linearly to 50% relative humidity at 40 °C
- Altitude: -100 meters to +3000 meters

Storage conditions:

- Ambient temperature: 5 °C to 40 °C
- Limited storage temperature (up to 3 months): -40 °C to 80 °C
-  Relative Humidity: 80% humidity for temperatures up to 31 °C, decreasing linearly to 50% humidity at 40 °C
-  Limited Humidity (3 months): 95% humidity (non-condensing) at 40 °C, functioning normally once reaching ambient conditions

Storage outside these conditions may result in improper welds and decreased battery life.



Power adapter: Use only with included power adapter or appropriate Versaweld tube welder replacement.

Using other power adapters could result in damage to the instrument, electrical shock/injury, and voiding the warranty.

Power adapter input: 50/60 Hz

Battery info:

- **Specifications:** 14.4 V, 6.8 Ah, 97.9 W, 4S2P lithium ion
- **Battery life:** > 63% of original capacity after 300 charge/discharge cycles
- **Capacity:** 150+ welds can be completed by a new battery when fully charged and used under the operating conditions outlined on the previous page

Instrument dimensions:

- Width: 7.6 inches (193 millimeters)
- Height: 5.2 inches (132 millimeters)
- Length: 12.1 inches (308 millimeters)
- Weight: 9 pounds (4.1 kilograms)

Cassette dimensions:

- Width: 3.2 inches (81 millimeters)
- Height: 1.1 inches (28 millimeters)
- Length: 8.6 inches (218 millimeters)
- Weight: 4.9 ounces (139 grams)

Tubing capacity*

Tubing sizes			Tubing materials			
Inner diameter (in)	Outer diameter (in)	Wall thickness (in)	Advantaflex	C-Flex	PharMed BPT	PVC
1/16" (0.063)	3/16" (0.188)	0.063"	—	—	X	—
3/32" (0.094)	5/32" (0.156)	0.031"	—	—	—	X
3/32" (0.094)	7/32" (0.219)	0.063"	—	—	X	—
5/32" (0.156)	7/32" (0.219)	0.063"	—	—	—	X
1/8" (0.125)	3/16" (0.188)	0.032"	—	—	X	X
1/8" (0.125)	1/4" (0.25)	0.063"	X	X	X	—
3/16" (0.188)	5/16" (0.313)	0.063"	X	X	X	—
1/4" (0.25)	3/8" (0.375)	0.063"	X	X	X	—

**Additional tube sizes and materials under investigation*

Durability performance

The life expectancy of the Versaweld tube welder depends on the tube welding frequency, laboratory environment housing the tube welder, tube sizes and materials, and type of weld (dry-to-dry, wet-to-wet, wet-to-dry, and type of fluid contained therein). If use is to occur outside the standard use conditions, as outlined in this manual, please contact Ensorcell to determine a modified service plan for replacing parts which may be affected by use conditions.

The Versaweld tube welder should be **serviced every 10,000 welds or every year**, according to the Service requirements (see the Servicing and technical support section). Laboratory environment can directly affect life expectancy if the laboratory environment is outside established parameters as dictated on pages 16-17. If the Versaweld tube welder is to be moved between hot and cold environments, allow up to 20 minutes for the tube welder to stabilize to the new environment before performing a new weld. Failure to do so could result in a failed weld or equipment damage.

Do not attempt to disassemble or repair the tube welder on site. Only qualified personnel are authorized to service the instrument, and any attempts to repair the tube welder will void the warranty and may increase the eventual cost of repair.

If problems occur with the tube welder operation or maintenance that are not covered in this manual, please contact Ensorcell at [ensorcell.bio/technical-support/](https://www.ensorcell.bio/technical-support/).

Power and charging

The Versaweld tube welder is only to be charged with an Ensorcell-issued power adapter or the warranty will be voided. Welding can be performed in both power modes, though the instrument must be plugged into the external power adapter to charge the internal battery. Complete charging of the internal battery takes less than four hours.



The tube welder is only to be charged with an Ensorcell-issued power adapter or the warranty will be voided.



WARNING: RISK OF FIRE AND BURNS

- Do not attempt to open, disassemble, or service this battery
- Do not crush, puncture, or short external contacts
- Do not dispose of in fire or water
- Do not expose to temperatures above 60 °C
- Dispose of properly: take to a certified recycling facility; never place lithium-ion batteries in the trash

A battery indicator icon is present in the upper left corner of the interface to indicate the amount of charge remaining.

To charge the Versaweld tube welder battery:

1. Place the instrument on a flat surface.
2. Plug the AC plug of the power adapter into a wall outlet.
3. Plug the DC jack of the power adapter into the charging port on the instrument.

Note: Be sure to update the firmware to the latest version before using the tube welder for the first time. Follow the update instructions via the settings menu.

Note: The USB-C port is not functional for instrument charging. It is only for completing firmware updates.

To power on the Versaweld tube welder:

1. Place the instrument on a flat surface.
2. Locate the power button on the lower front surface of the instrument.
3. Press the power button and release it.
4. Wait for the display to power on and load the interface.

Note: After powering on for the first time, the firmware should be updated to the latest version via the settings menu.

Note: The instrument will go into power saving sleep mode after 15 minutes with no activity.





To power off the Versaweld tube welder :

1. Press and hold the power button on the tube welder for **five (5) seconds**, then release.
2. The display will power off.

Digital interface use and navigation

The Versaweld tube welder uses a touchscreen to display the current weld type and to select the parameters used for each weld. See below for a summary of the different screen functions and iconography.

Summary of symbols

-  Settings menu
-  Close window
-  Battery level
-  Confirm

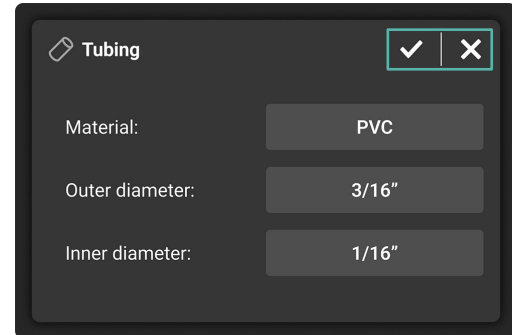
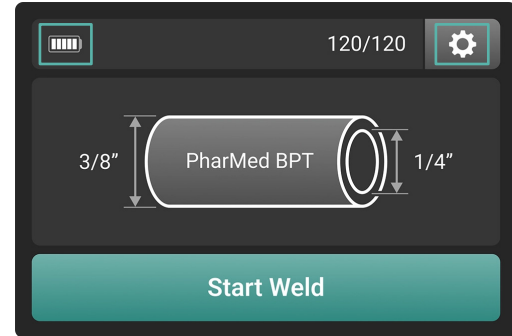

Home screen

The home screen will launch once the instrument has finished booting up. Tap the "X" button in the top right corner of other screens to return to this screen.

The home screen contains the following information:

1. **Battery charge level** - an icon in the upper left corner
2. **Weld quantity remaining** - a fraction of the total weld capacity of the cassette*
3. **Settings button** - gear icon in the upper right-hand corner
4. **Tubing material selection** - on the central tube graphic
5. **Tubing OD selection** - left of the central tube graphic
6. **Tubing ID selection** - right of the central tube graphic
7. **Central tubing specifications button** - surrounding the tube graphic, used to change the current weld setup
8. **Start weld button** - on the lower portion of the screen

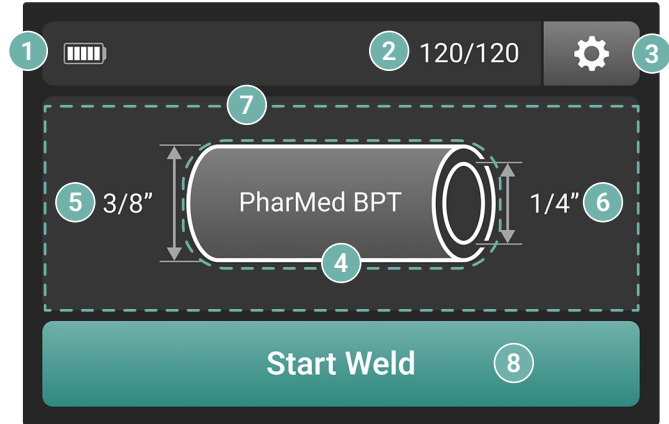

*Cassette weld capacity may vary; to verify the capacity of a cassette, load it into the instrument and check the number in the upper right corner of the home screen.

Welding processes

The Versaweld tube welder performs sterile dry-to-dry, dry-to-wet, and wet-to-wet welds with thermoplastic tubing. Using the following instructions to select tube size and material, the instrument connects fluidic systems by melting and joining disconnected tube ends.

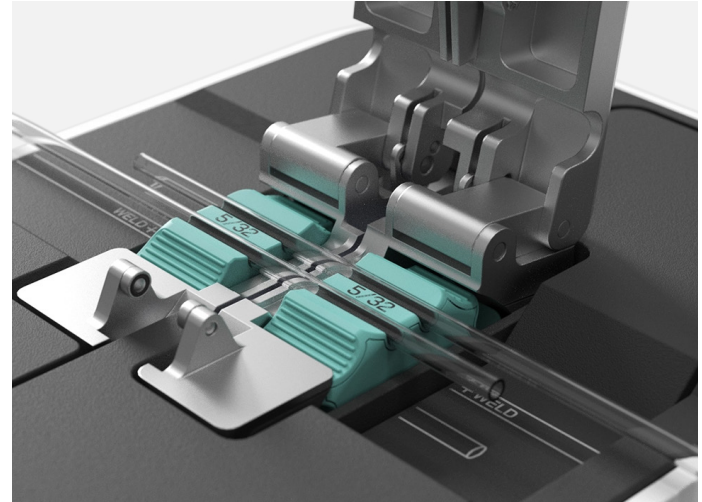

Tube selection

The tube welder allows the user to weld tubes of various sizes and materials. Tubes being welded together must be the same size and material. To perform a weld, the instrument must first be set to the correct tube material, outer diameter (OD), and inner diameter (ID) to ensure quality weld performance.

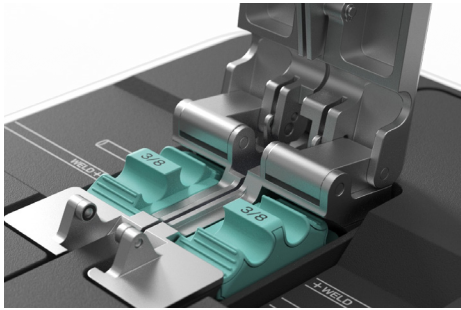

Step 1

Lift both clamps. Verify no tubes are present in the tube selector wheels.

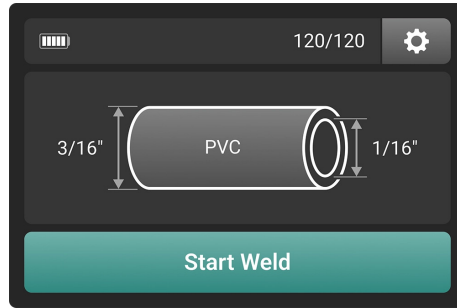

Step 2

On the home screen, tap the central button, the image of a tube.

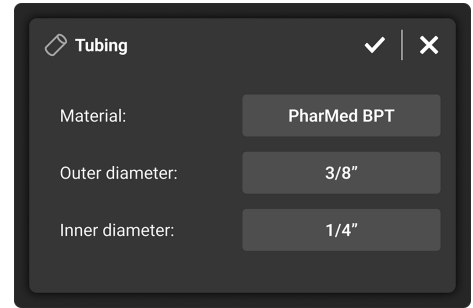

Step 3

Select the intended material, OD, and ID (see the Tubing gauge section), then tap the checkmark to confirm your selection. Allow the clamps to adjust.

Wheel position

Step 1

Verify the tubing specifications on the interface are correct.

Step 2

With both clamps raised, the tube selector wheels are accessible.

Step 3

Rotate the tube selector wheels in either direction until both wheels reflect the same outer diameter of the tube shown on the interface. (This is the number on the left side of the home screen.)

Step 4

Verify that both wheels are set to the same value based on the text marked on the wheels, and verify this number matches the interface. If there is a mismatch of selector wheel settings or dimensions selected on the interface, an error pop-up will occur.

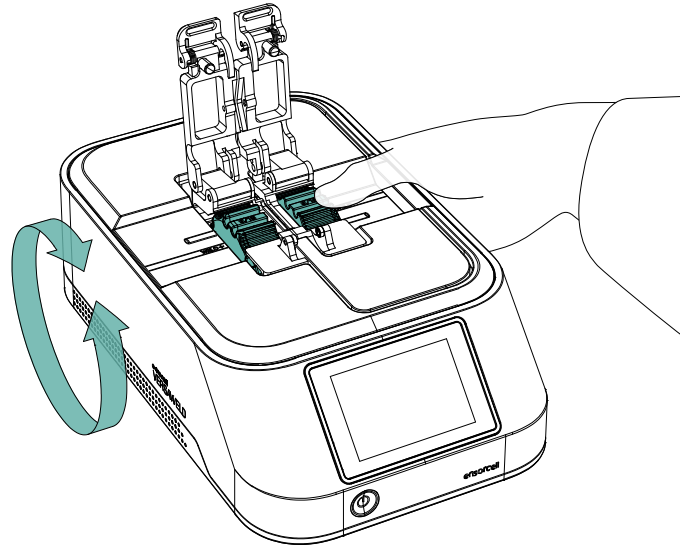

Placing and securing tubes

Step 1

With both clamps raised, verify the interface and the tube selector wheels are set to the correct settings.

Step 2

Place tubing clamps (not included) on any wet tubes to be welded, approximately six (6) inches before the desired weld site of the tubes, to hold the tubes closed.



Apply tubing clamps per laboratory SOPs to prevent contamination or sample leakage in the event an error occurs in the weld process.

Step 3

Put tube one (1) to the right of the instrument and place the end of tube one (1) through the upper slots of the tube selector wheels, from right to left. Approximately one (1) inch of tubing at minimum must protrude beyond the end of the left tube selector wheel.

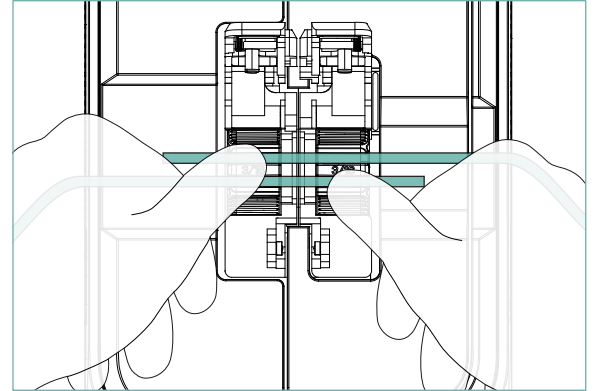
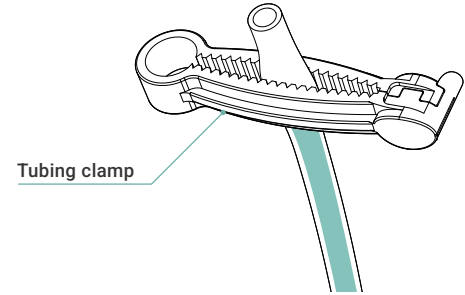

Placing and securing tubes

Step 4

Put tube two (2) to the left of the instrument and place the end of tube two (2) through the lower slots of the tube selector wheels from left to right. Approximately one (1) inch of tubing at minimum must protrude beyond the end of the right tube selector wheel.

Step 5

Close the clamps and press the end of the clamps down, locking them in place. There should be a slight click at the complete closing of the clamp. The clamp lever should be parallel to the instrument surface.

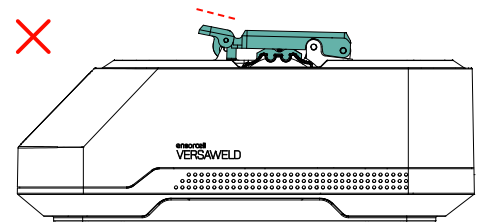
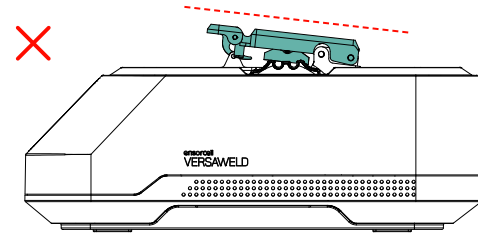
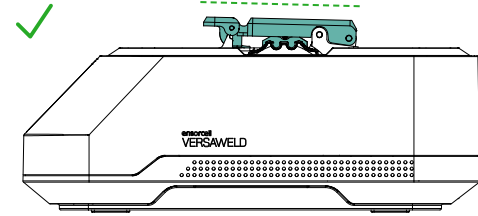
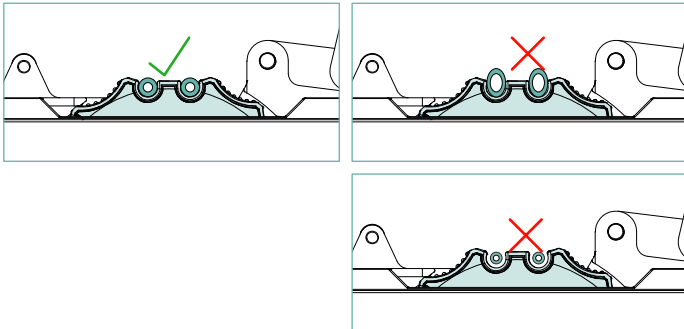

Welding tubes

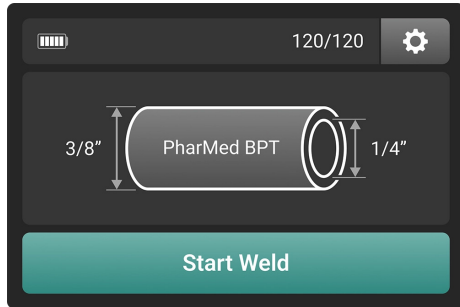

Step 1

After completing the operations for tube selection and placing and securing the tubes, tap the "Start Weld" on the home screen.

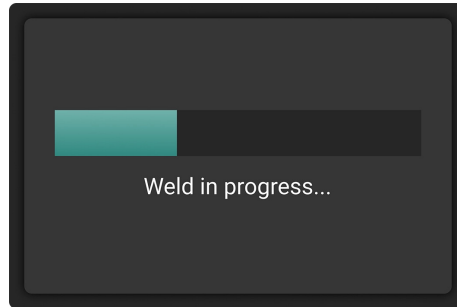

Step 2

Wait while the instrument performs the welding operation. This will take approximately thirty (30) seconds or less.



Do not try and reach the ribbon during the weld operation.



Do not attempt to open the clamps.

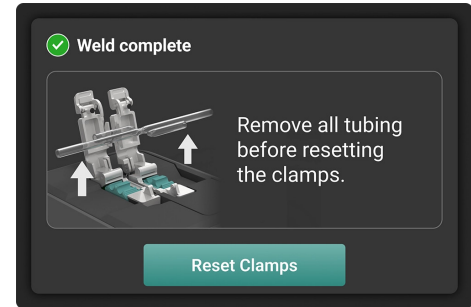

Step 3

Once the weld is complete, it will display a message on the interface. Open both clamps and remove the tubes from the tube selector wheels.

Welding tubes

Step 4

Remove the waste ends from the tube selector wheels.

These are sealed along the cut edge. Verify that the desired tubes are connected and the correct tube ends made waste.

Note: Instructions on weld inspection and popping open the weld are located on the following page.

Step 5

Dispose of the waste ends per laboratory SOP.

Step 6

Verify all tubes were removed from the clamps. Tap the "Reset Clamps" button and allow the tube welder to reset the clamps to the starting position.

Step 7

The tube welder will return to the home screen and the "Start Weld" button will light up when the instrument is ready to perform another weld.

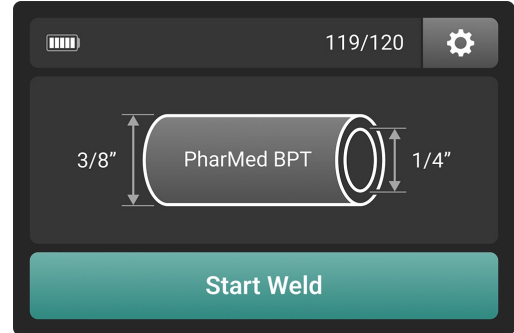
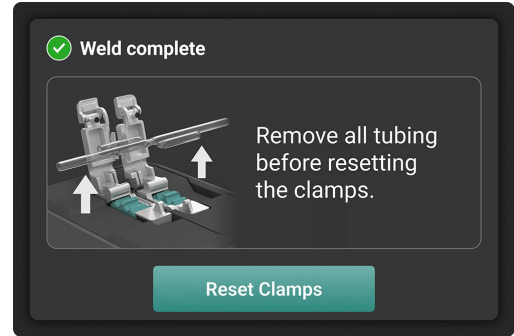

Weld integrity inspection

Step 1

Once welded, remove the tubes from the tube selector wheels and examine the weld.

Step 2

Rotate the weld through a complete circle, focusing on the join line.

Step 3

Determine if the tubes appear aligned at the joint throughout rotation. The weld should not have any misalignment, cracks, holes, or bubbles.

Step 4

If the weld looks acceptable, pinch or roll the tube at the weld until the weld pops open. This will open a path to merge the samples.

Note: *If the weld does not pop open or the weld is misaligned or poor quality, see the Troubleshooting section for malformed welds.*

Step 5

Inspect the weld area for any sign of leakage.

Note: *Leakage may compromise sterility or the system. Please follow laboratory SOP for compromised sterility and waste cleanup for fluid leakage.*

Step 6

If tubing clamps were placed on the samples to isolate the section of tubing being welded, they can be removed.

Features and functions

Pop-up windows

Pop-up windows will occur when the Versaweld tube welder requires input to continue. Messages may occur for errors, instrument faults, or to guide the user through the replacement of a consumable.

Example A

If a pop-up window appears, read the message and follow the instructions. Once the required action is completed, the button at the bottom of the pop-up window will light up to proceed.

Example B

If there are no additional instructions, close the pop-up window by tapping the "OK" or "Close" button on the bottom of the pop-up window.

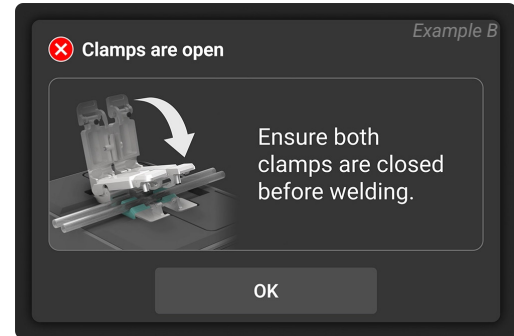
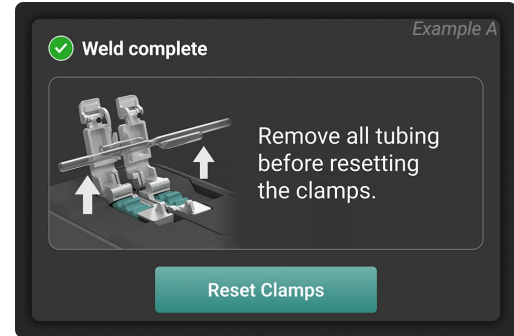

Cassette replacement

When the cassette has been depleted, the instrument will display a zero for weld quantity remaining (e.g. 0/120). The interface will display a prompt that the cassette is empty and needs to be replaced.

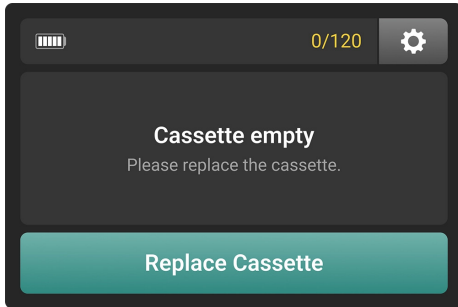

Step 1
Tap the "Replace Cassette."



Step 2
Raise the clamps and remove all tubing from the instrument. Close the clamps.

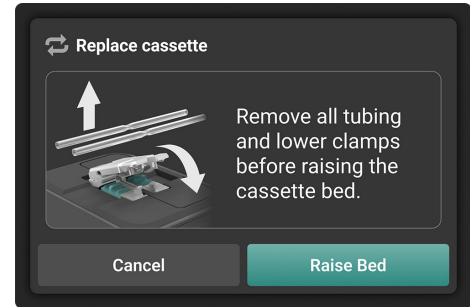

Step 3
Tap the "Raise Bed" button. The button will only become active once the clamps are lowered.

Cassette replacement

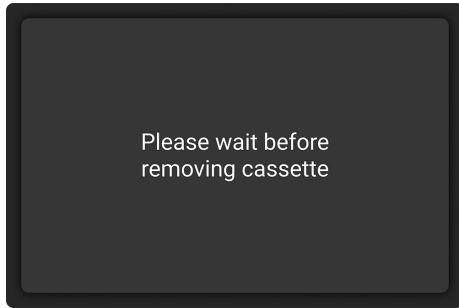

Step 4

Wait until the bed is fully raised and the interface does not display the message to wait.

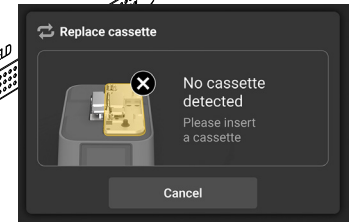
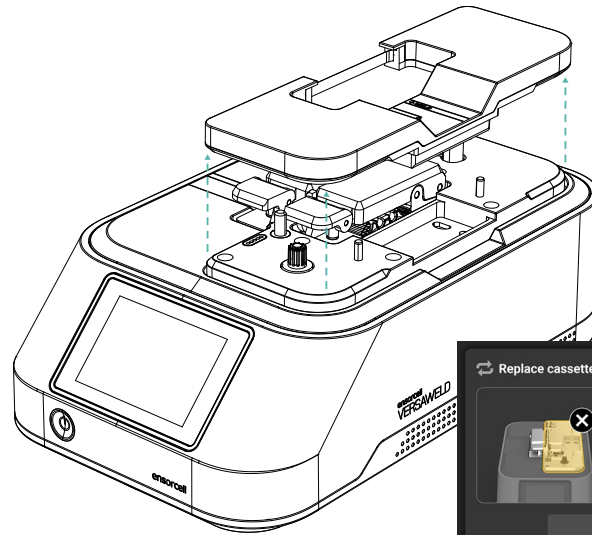

Step 5

Lift the cassette from the cassette bed to remove it. Once the cassette is removed, the interface will display the alert above. This alert will appear whenever the tube welder does not detect a cassette installed.

Cassette replacement

Step 6

Dispose of fully consumed cassettes per laboratory SOP, with consideration to any potential biohazards on the used ribbon. Partially consumed cassettes may be reinstalled at a later time.

Note: Removing a partially consumed cassette consumes one (1) weld worth of ribbon in order to tension the cassette after installation and ensure ribbon cleanliness.

Step 7

Remove new cassette from its packaging and place it on the cassette bed. The exposed ribbon should naturally fit between the two clamps.

Note: Do not handle the cassette ribbon. The ribbon may have some slack in it. This is normal, and the ribbon will be placed under tension when the cassette is lowered into the instrument.

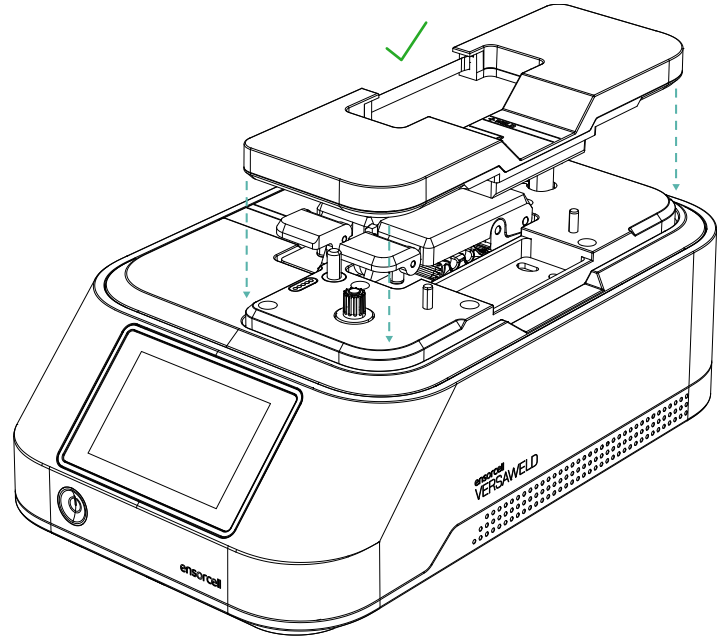

Cassette replacement

Step 8

Tap the "Lower Bed" button and allow the tube welder to identify the new cassette. The tube welder will identify the new cassette and return to the home screen, with the "Start Weld" button available to tap. The number of available welds in the upper right hand corner of the screen will update to show the remaining welds.

Note: If the instrument is not able to read the new cassette, follow the on-screen prompts. Possible errors might include the replaced cassette having no remaining welds, the firmware needing an update, or damaged detection pins (see the Troubleshooting section).

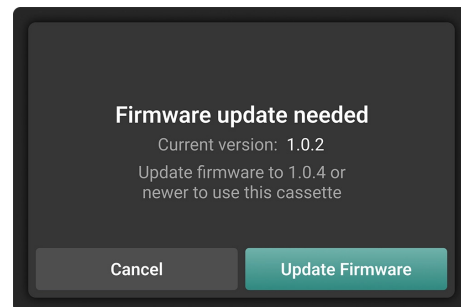
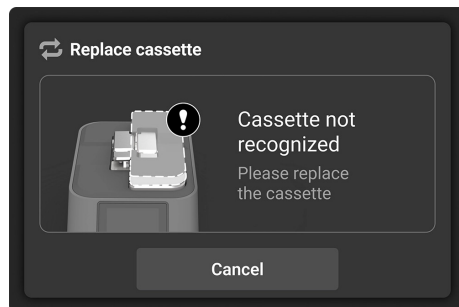
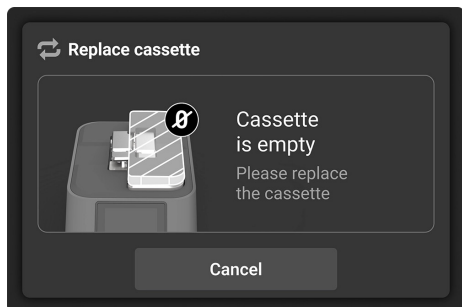
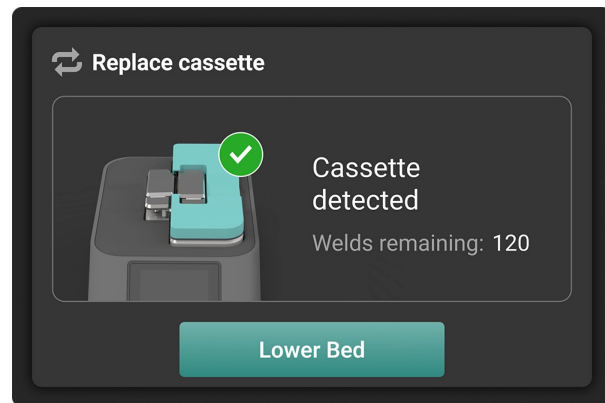

Tube gauge use

If the size of the tubing to be welded is not labeled on the tubing itself or on the original packaging, and the size is unclear, the tube gauge provided with the Versaweld tube welder can be utilized to determine the tubing size. This gauge may be stored on the underside of the instrument when not in use. For a replacement gauge, contact Ensorcell for part number **VSWGa-02001**.

Step 1

Lift the front edge of the tube welder and locate the tube gauge, which is located in a recess on the underside of the instrument.

Step 2

The tube gauge is held in place with magnets. Slide it free of the recess and return the tube welder to its flat position.

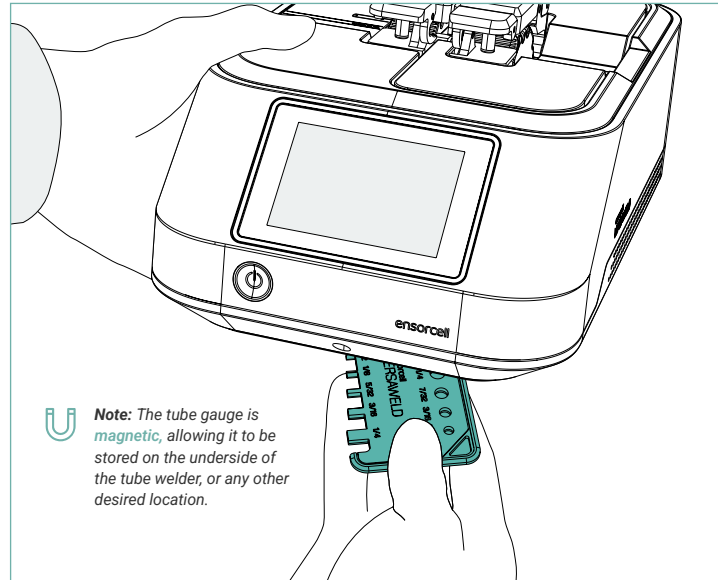

U *Note: The tube gauge is magnetic, allowing it to be stored on the underside of the tube welder, or any other desired location.*

Tube gauge use

Step 3

Using a clean portion of tubing, thread the tube through the holes to find the correct OD. It should fit snugly, but not need to be bent or crushed to fit through the hole. This is the **tubing OD**. The diameter measurement of each hole is printed in inches below the hole. The measurements are displayed in fractions on one side and decimals on the other.

The tube end should look as shown when the appropriate size is found.

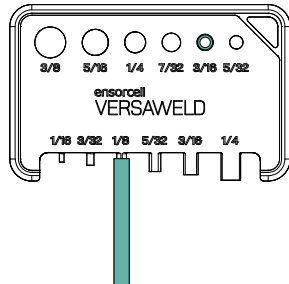

If the tube end is loose fitting or deformed as shown here, the size is incorrect.

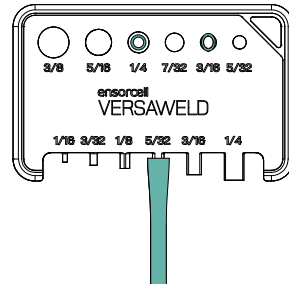

Step 4

Using the same clean portion of tubing, feed the tubing over each tooth on the edge of the tool, one by one, starting at the smallest end. The cross-section should remain a true circle and not have an elliptical shape when on the correct tooth of the tube gauge.

Step 5

When the tube fits snugly but is not deformed, note the measurement beside the tooth. This is the **tubing ID**. Verify that the tubing OD is larger than the tubing ID. If that is not the case, repeat steps 3-5.

Step 6

Return the tube gauge to the bottom of the tube welder or other preferred storage location. Once it is pressed into the recess on the bottom of the tube welder, the magnets should hold it in place.

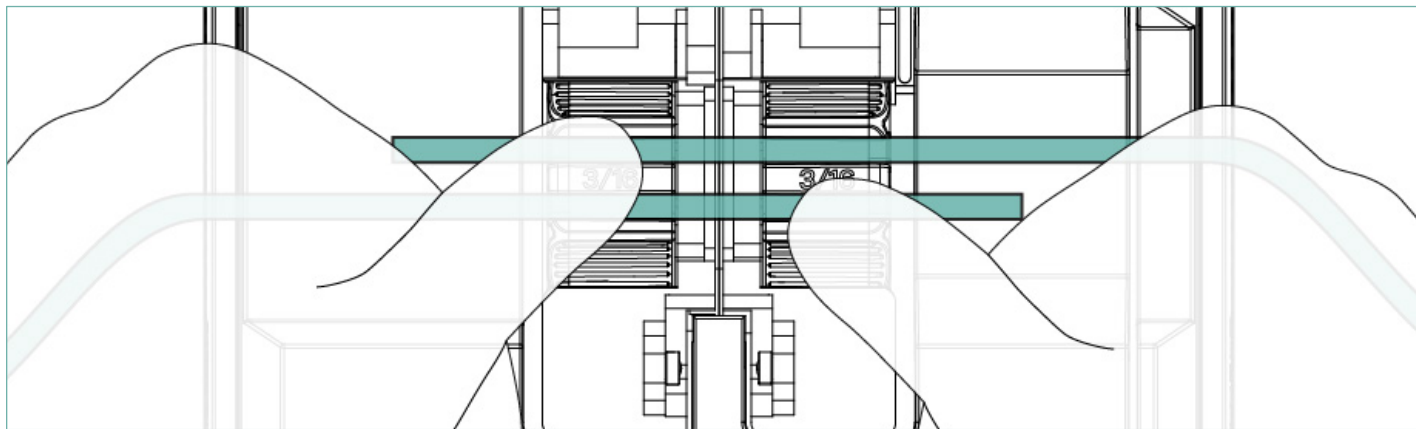

Weld tubing guides

The surfaces of the Versaweld tube welder and cassette each feature laser etched guidelines to assist in tube placement prior to welding.

The upper left and lower right tube segments indicate the placement of waste ends of tubing. Waste tube should extend approximately one (1) inch past the edge of the second wheel.

The upper right and lower left full tubes indicate the portion of tubing that are to be joined together when a weld is performed.

Settings

The Versaweld tube welder settings menu allows for adjustments to the instrument's settings. This screen can be accessed by the user to adjust the current weld settings, access favorites, perform firmware updates, and change cassettes.

To access the settings menu:

Step 1

Touch the gear icon in the upper right-hand corner of the screen.

Step 2

Use the arrows on the right-hand side to scroll through the options to find the setting category of interest.

Step 3

Tap the desired category to review the current instrument setting or make a desired change.

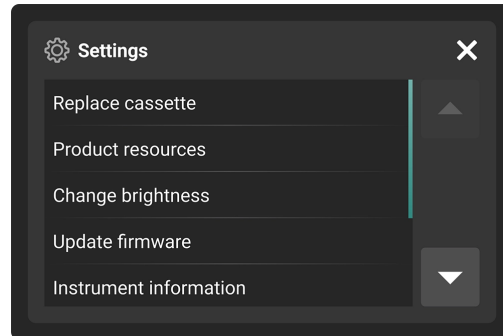
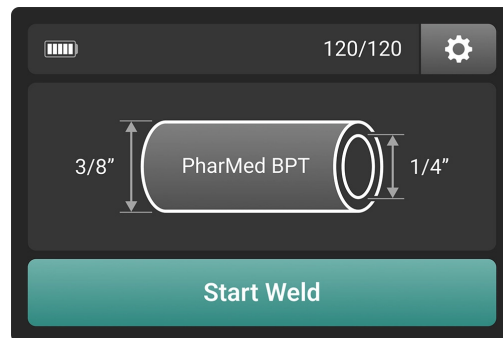

To change cassettes:

(See the Cassette changing section.) The menu may be used to remove a partially consumed cassette. Cassettes removed this way may be stored and used at a later time. Removing a cassette before it is entirely consumed will consume one weld's worth of material.

To access product resources:

Step 1

Select "Product resources" from the settings menu.

Step 2

Scan the QR code. This code will open a webpage where digital versions of the user guides and other related technical notes are available to be viewed or downloaded.

Step 3

Tap the "Close" button to return to the settings menu.

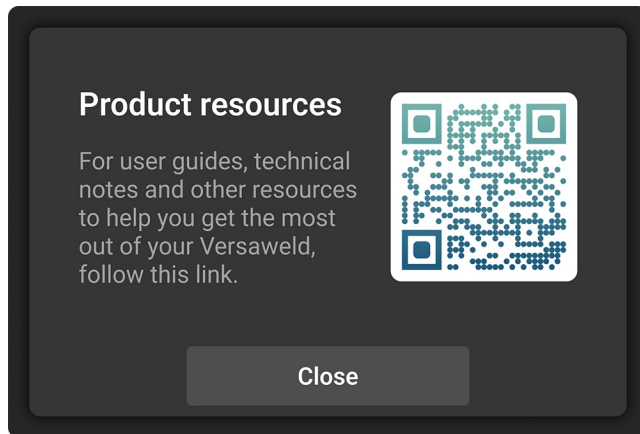

To change screen brightness:

Step 1

Select "Change brightness" from the settings menu.

Step 2

Adjust the screen brightness by pressing and dragging the slider on the screen.

Step 3

Tap the checkmark icon in the upper right corner of the screen to confirm the brightness level and return to the settings menu.

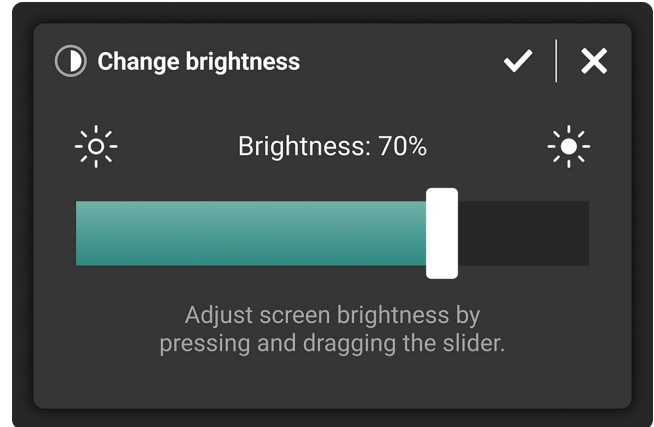

To perform firmware updates:

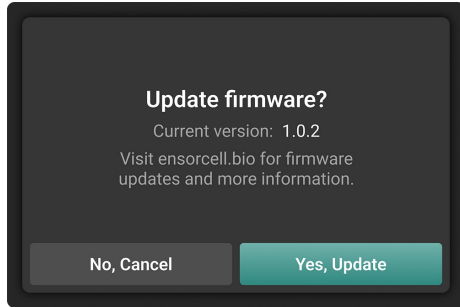

Step 1

Using a desktop or laptop computer, go to ensorcell.bio/versaweld to view and download the latest firmware update. Select "Update Firmware" from the settings menu on the tube welder. Tap "Yes, Update" to continue the update.

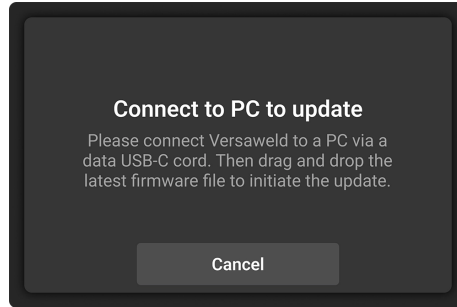

Step 2

Turn the tube welder around and locate the USB-C data port. Using a USB-C data transfer cable (not provided), connect one end to the tube welder's USB-C data port and connect the other end to the computer's USB-C port.

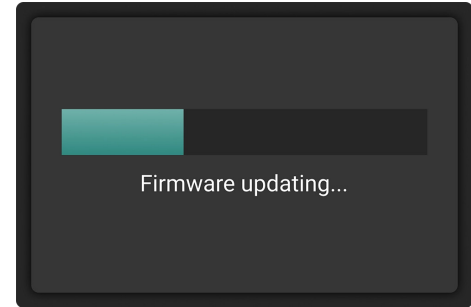

Step 3

Drag and drop the firmware file into the "Versaweld" drive on the computer. Wait as the tube welder performs a firmware update.

To perform firmware updates:

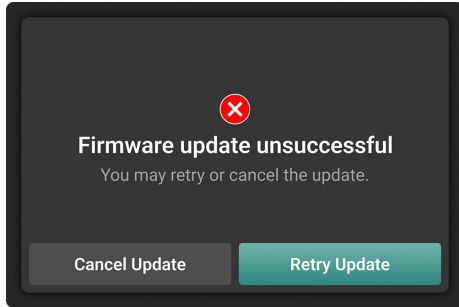

Step 4

If the update fails, tap the "Retry Update" button.
If the update is successful, proceed to Step 5.

Note: If the update fails again, review Step 1 on the previous page.

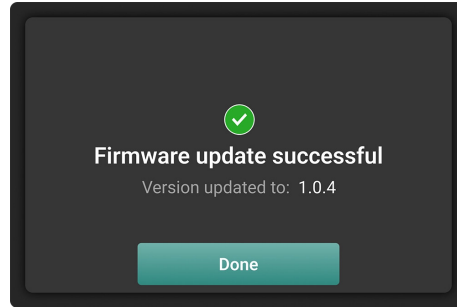

Step 5

Once update is successful, confirm that the interface displays the correct firmware version number and tap "Done" to complete the update process.

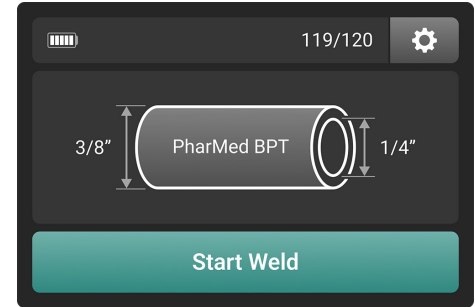

Step 6

The USB-C cable can now be removed from the tube welder. The instrument can be returned to the normal operation location.

To access instrument information:

Step 1

Select "Instrument information" from the settings menu.

Step 2

The screen will display the hardware version, firmware version, instrument and cassette serial numbers, and other information related to the instrument.

Step 3

Tap the "X" icon in the upper right corner of the screen to return to the settings menu.

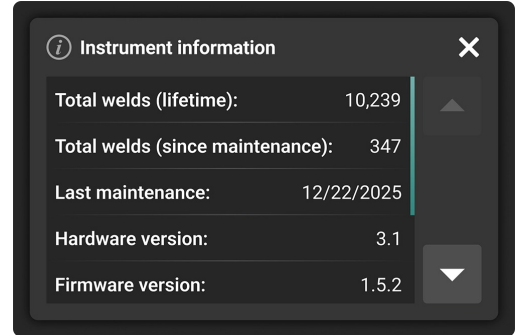

To access technical support:

Step 1

Select "Technical support" from the settings menu.

Step 2

Scan the QR code. This code will open a website with the contact information for Ensorcell technical support. Tap "Close" to return to the settings menu.

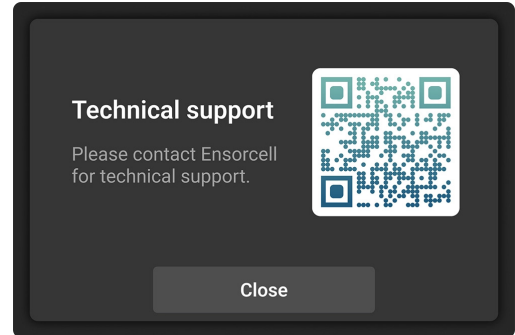

Troubleshooting guide

If the observed issue is not found in the following list or the suggested solutions do not resolve the issue, contact Ensorcell at ensorcell.bio/technical-support/.

The cassette does not rise when "Raise Bed" is selected on the screen:

- Verify the cassette bed is not already raised—a lowered cassette should be flush to the top of the welder
- Verify a cassette is present—the raised empty cassette bed should be flush with the top of the instrument
- Verify nothing is resting on the top surface of the tube welder

Cassette does not lower:

- Wait for the cassette to lower—the lowering and tensioning process will take several seconds
- Power the tube welder off and then on again

The Versaweld tube welder will not power on:

- Verify the tube welder is plugged in and the power adapter is connected to a wall socket
- Verify the AC plug is connected to the box of the power adapter
- Hold the power button for five (5) seconds, then release it—press the power button again

Weld does not complete:

- Review the interface for error messages and rectify them if necessary
- Verify the clamps are secure and latched closed
- Verify the tube selection wheels are set to the correct tubing size
- Verify the presence of a cassette with remaining welds

Wrong tube ends welded:

- Switch the tubes in the instrument so the tube that was previously stretched across upper grooves of the tube selector wheels is now in the lower grooves and change the lower tube to the upper grooves—do not otherwise alter the tube or sample orientation

Weld is incomplete, crooked, or otherwise malformed:

- Ensure individual tubing clamps placed on the tubes prior to welding are in place, preventing fluid flow
- Verify the tubes being welded are the same OD and ID as selected on the tube welder
- Verify the tubes being welded have matching ODs and IDs
- Verify the tube welder is set to the correct tube material type
- Cut the welded area from the tube to remove the bad quality weld. Repeat the welding process, per laboratory SOP

Cannot select required tube settings:

- Verify with the Tubing capacity chart (see Tubing capacity section) to ensure the tube is listed as acceptable for use in the instrument
- Review tubing information from manufacturer of tube in use to verify correct size
- Verify the tube diameter using the tube gauge included with the tube welder
- Verify both of the tube selector wheels are set to the same size and the size selected corresponds to the tube OD

Cannot find tube outer or inner diameter:

- Use the tube gauge included with the tube welder (see the Tube gauge section)
- Review the length of the tubing to determine if tubing size is listed on material
- Review the tube packaging to determine if tubing size is listed

Tube selector wheels will not turn:

- Verify both clamps are lifted and the bed is lowered

The Versaweld tube welder will not charge:

- Remove the power adapter from the back of the instrument and inspect the charging port for foreign material or damage to the DC jack
- Verify the wall socket is providing power
- Inspect the power cord and ensure the cord is connected to the tube welder power adapter
- Verify the cord in use is the Versaweld tube welder cord
- Review the cord for damage or exposed wires

Screen frozen:

- Hold the power button for 5 seconds, then release it for five (5) seconds and press the power button once

Excessive smoke:

- Verify the correct tube size and material is selected on the tube welder
- Inspect the cassette for damage

Cassette not recognized:

- Remove the cassette from the cassette bed and inspect the ribbon to verify there is still unused ribbon
- Flip the cassette to view the data pins on the back—ensure the pins are clean and undamaged

Clamps do not close:

- Verify the bed is lowered
- Review that the tube selector wheel size and the tubes inserted match
- Ensure the tubes are placed fully in the tube selector wheels
- Inspect around the clamps for debris and scrap tubing that would prevent closure
- Verify the front of the clamp is pressed down and the end of the clamp is hinged closed, and hooked securely, with the front of the clamp parallel with the top surface of the instrument

Cleaning instructions

The Versaweld tube welder is to be cleaned as needed, when exposed to possible debris or contaminants. Prior to cleaning, ensure the unit is powered down and disconnected from any power source.

Dampen a cloth or a cotton swab with one of the following cleaning solutions:

- Mild soap solution
- 70% ethyl or isopropyl alcohol solution

Wipe the surfaces of the tube welder with the damp cloth while directing moisture and debris away from openings on the instrument.



Cleaning should move away from the cutting area and cassette bed area whenever possible.



Use a swab to clean crevices and hard to reach areas. Avoid oversaturating the swab.



Allow the tube welder to dry completely before attaching the power adapter or powering on the instrument.



Do not spray cleaning solutions directly on the tube welder or in the interior of the instrument.



Do not allow liquids to enter into the tube welder. Doing so may cause damage and void the warranty.

Servicing and technical support

For service and technical support, please contact Ensorcell at **ensorcell.bio/technical-support/**. Please be prepared to provide the Versaweld tube welder serial number, available on the label on the underside of the instrument, as well as a detailed description of the problem.



Do not attempt to disassemble or repair the instrument on site. The Versaweld tube welder may only be serviced by authorized personnel. Any attempts to service the instrument by unauthorized personnel will void the warranty (refer to the service agreement for the instrument).

If technical support determines returning the Versaweld tube welder is necessary, Ensorcell will supply the packaging material and shipping label.

Standard accessories with a Versaweld tube welder

Description	Item order number
Versaweld tube welder	VSWIr-02001
This product may be covered by one or more patents pending.	
Cassette refill	VSWCa-02001
This product may be covered by one or more patents pending.	
Tube gauge	VSWGa-02001
Power adapter	VSWPa-02001
Shipping case	VSWSh-02001

©2026 Re:Build Innovations, LLC

ENSORCELL and VERSAWELD are trademarks of Re:Build Innovations, LLC.

These products may be covered by one or more patents pending.

Ensorcell

161 Worcester Road, Suite 606
Framingham, MA 01701



Scan the QR code to visit Technical support
at ensorcell.bio/technical-support/.

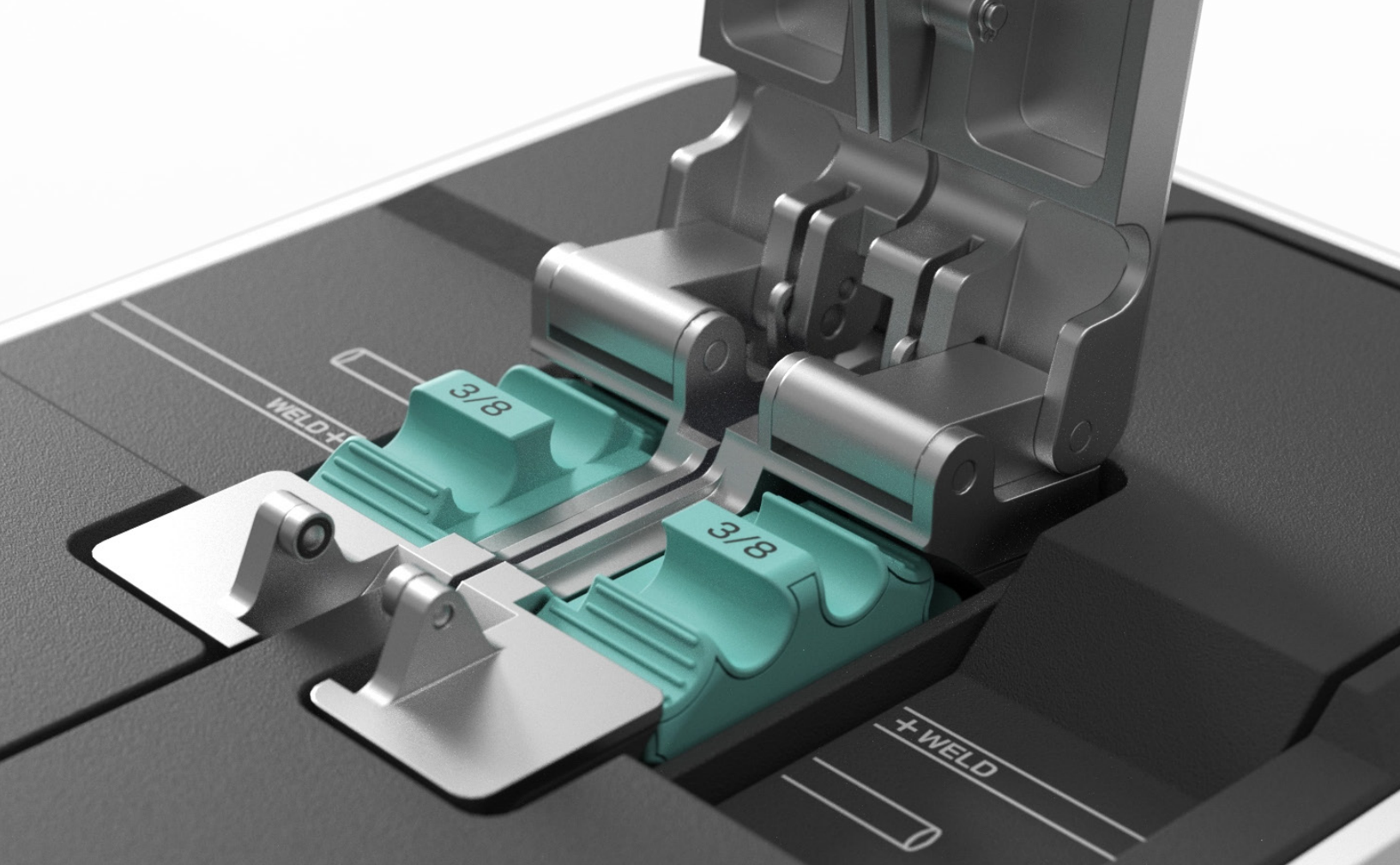

ensorcell™

Life science tools reimagined.